

**Up to  
55% OFF  
List Price**

Cut Time in Half with the Dorian

---

# SLOT GRIP

---

Cut Off System

***Improved Blade Features a "Positive Stop" !***

Inserts are securely held in Slot Grip Positive Stop Blades by a tapered locking system featuring a "Positive Stop" that prevents insert drift and the blade pocket from spreading once the insert is firmly in place.

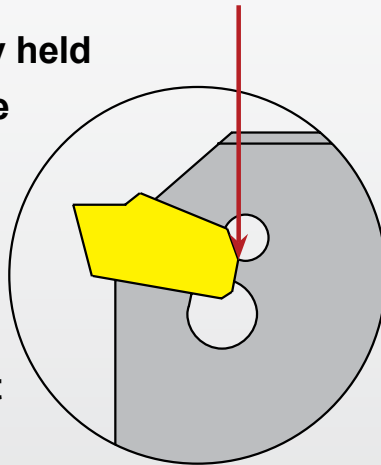

**Up to  
55% OFF  
List Price**

Designed for use with SGTN cut-off inserts and SGIH cut-off blade.

The insert's cutting edge repeats accurately and as a result prevents insert splitting under heavy feed and shock loads. The blade and insert geometry permits free chip flow, minimizing insert breakage due to chip build-up.

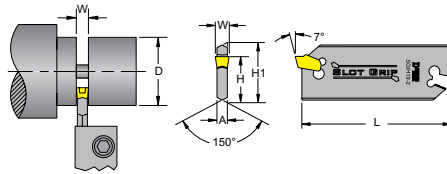

### Slot Grip Positive Stop Blades

Desc.	Part No. 733101-	List Price	Sale Price	Insert Width, W		D Max		A		L		H		H 1	
				in	mm	in	mm	in	mm	in	mm	in	mm	in	mm
SGIH19-2	62950-Z30A1	\$72.16	<b>\$41.23</b>	.087	2	1.57	39.9	.063	1.57	3.38	85.9	.618	15.7	0.75	19.1
SGIH26-2	62951-Z30A1	\$85.95	<b>\$49.11</b>	.087	2	2.00	50.8	.063	1.57	4.33	110.0	.842	21.4	1.02	25.9
SGIH26-3	62952-Z30A1	\$85.95	<b>\$49.11</b>	.122	3	3.00	76.2	.094	2.39						
SGIH26-4	62953-Z30A1	\$85.95	<b>\$49.11</b>	.161	4	3.15	80.0	.125	3.18						
SGIH26-5	62954-Z30A1	\$85.95	<b>\$49.11</b>	.201	5	3.15	80.0	.156	3.96						
SGIH26-6	62955-Z30A1	\$85.95	<b>\$49.11</b>	.252	6	3.15	80.0	.203	5.16	5.90	149.9	.984	25.0	1.25	31.8
SGIH32-3	62956-Z30A1	\$99.42	<b>\$56.81</b>	.122	3	3.94	100.0	.094	2.39						
SGIH32-4	62957-Z30A1	\$99.42	<b>\$56.81</b>	.161	4	3.94	100.0	.125	3.18						
SGIH32-5	62958-Z30A1	\$99.42	<b>\$56.81</b>	.201	5	4.71	119.6	.156	3.96						
SGIH32-6	62959-Z30A1	\$99.42	<b>\$56.81</b>	.252	6	4.72	119.9	.203	5.16	5.51	140.0	.268	6.81	.312	7.92
SGIH32-8	62960-Z30A1	\$147.32	<b>\$84.18</b>	.315	8	5.51	140.0	.268	6.81						
SGIH32-9	62961-Z30A1	\$147.32	<b>\$84.18</b>	.378	9	5.51	140.0	.312	7.92						

The square shank design of the Cut-Off toolholder ensures a precise center height of the insert with respect to the center of the work-piece, when the toolholder is mounted directly on the CNC turret.

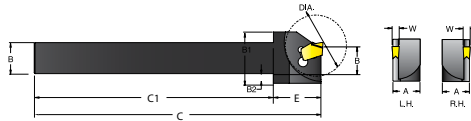

The two piece clamp style of the Neutral Cut-Off Toolholder provides a precise and rigid blade locking and easy mounting of the tool into manual and CNC turrets.



### Square Shank Toolholders

Description	Part No. 733101- Right Hand	List Price	Sale Price	B	Max Dia	W	Insert Used
SGTHR-9,5-2	63000-Z30A1	<b>\$70.52</b>	<b>\$50.37</b>	0.375	1.109	.087 & 0.93 (2mm & 2.4mm)	SGTN-2 or SGTN-2.4
SGTHR-12,7-2	63002-Z30A1	<b>\$76.34</b>	<b>\$54.53</b>	0.500	1.172		
SGTHR-16-2	63004-Z30A1	<b>\$82.16</b>	<b>\$58.69</b>	0.625	1.172		
SGTHR-19-2	63006-Z30A1	<b>\$98.71</b>	<b>\$70.51</b>	0.750	1.266		
SGTHR-12,7-3	63010-Z30A1	<b>\$76.34</b>	<b>\$54.53</b>	0.500	1.266	.120 (3mm)	SGTN-3
SGTHR-16-3	63012-Z30A1	<b>\$82.16</b>	<b>\$58.69</b>	0.625	1.406		
SGTHR-19-3	63014-Z30A1	<b>\$98.71</b>	<b>\$70.51</b>	0.750	2.062		
SGTHR-25,4-3	63016-Z30A1	<b>\$123.91</b>	<b>\$88.51</b>	1.000	1.328		
SGTHR-19-5	63024-Z30A1	<b>\$98.71</b>	<b>\$70.51</b>	0.750	1.531	.187 & .200 (4.8mm & 5mm)	SGTN-4.8 or SGTN-5
SGTHR-25,4-5	63026-Z30A1	<b>\$123.91</b>	<b>\$88.51</b>	1.000	3.000		

### Neutral Cut-Off Toolholders

Description	Part No. 733101-	List Price	Sale Price	Shank Size	Blade Used
SGTBN12,7-2	62970-Z30A1	<b>\$171.52</b>	<b>\$78.41</b>	0.500	SGIH19-2
SGTBN16-2	62971-Z30A1	<b>\$171.52</b>	<b>\$78.41</b>	0.625	
SGTBN16-5	62972-Z30A1	<b>\$171.52</b>	<b>\$78.41</b>	0.625	SGIH26-2 THRU SGIH26-6
SGTBN19-5	62973-Z30A1	<b>\$180.73</b>	<b>\$82.62</b>	0.750	
SGTBN19-6	62974-Z30A1	<b>\$180.73</b>	<b>\$82.62</b>	0.750	
SGTBN25-4-6	62975-Z30A1	<b>\$186.22</b>	<b>\$85.13</b>	1.000	SGIH32-3 THRU SGIH32-9
SGTBN31,8-6	62976-Z30A1	<b>\$191.27</b>	<b>\$87.44</b>	1.250	
SGTBN38,1-6	62977-Z30A1	<b>\$256.56</b>	<b>\$117.28</b>	1.500	

### SGTN Inserts

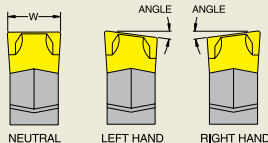

### Application

- Quickly inserted into adjustable blades
- For cut-off and grooving
- Fair for interrupted cuts

### Chipbreaker Geometry

- Reduced machining force
- Controlled, coiled chip flow
- Higher material removal rate

### Groove and Cut-Off SGTN Inserts

Desc.	Insert Grade	Part No. 733101-	List Price	Sale Price	Insert Size	Lead Angle	Width ± .004 mm in
SGTN-2- DK25		82220-Z30A1	\$7.61	<b>\$4.08</b>	2mm	0°	2mm (.087")
SGTN-2- DASK25B		82223-Z30A1	\$11.13	<b>\$5.96</b>			
SGTN-2- DC656		82222-Z30A1	\$9.95	<b>\$5.33</b>			
SGTN-3- DK25		82224-Z30A1	\$7.61	<b>\$4.08</b>	3mm	0°	3mm (.120")
SGTN-3- DASK25B		82227-Z30A1	\$11.13	<b>\$5.96</b>			
SGTN-3- DC656		82226-Z30A1	\$9.95	<b>\$5.33</b>			
SGTN-4- DK25		82228-Z30A1	\$8.65	<b>\$4.63</b>	4mm	0°	4mm (.160")
SGTN-4- DASK25B		82231-Z30A1	\$12.83	<b>\$6.87</b>			
SGTN-4- DC656		82230-Z30A1	\$10.60	<b>\$5.68</b>			
SGTN-5- DK25		82232-Z30A1	\$9.02	<b>\$4.83</b>	5mm	0°	5mm (.200")
SGTN-5- DASK25B		82235-Z30A1	\$13.42	<b>\$7.19</b>			
SGTN-5- DC656		82234-Z30A1	\$10.35	<b>\$5.54</b>			

Insert Grade	Coating Specifications	ISO	Material to Machine	Insert Grade Specifications
DC656	CVD COATED CVD TiN/ TiC-TiN	P15-P35	Free Cutting Steel, Low Carbon Steel Alloy Carbon Steel, Alloy Steel under 48 HRC 400 Series Stainless Steel	First Choice for general turning applications on ferrous metals and stainless steel, at medium cutting
		M20-M35		
DK25	NON COATED	N10-N25	Copper/Brass Stainless Steel Austenitic Cast Iron High Temper Alloys	First Choice for roughing turning applications on ferrous metals and stainless steel, at low cutting sfm, wet Condition.
		M30-M45		
		K15-K25		
		S10-S25		
DASK25B	PVD COATED PVD TiN+TiAlN+TiN	P10-P25	Free Cutting Steel, High Temper Alloys Stainless Steel Austenitic Cast Iron Copper/Brass	First Choice for general turning applications on ferrous metals and stainless steel, at medium cutting sfm.
		M15-35		
		K05-K20		
		S10-S25		

### Toolholder, Blade & Insert Sets

Set Desc.	Set Part No. 733101-	List Price	Sale Price	(1) Blade	(10) Inserts	(1) Toolholder
SGTBN19-5S	85326-Z30A1	\$366.18	<b>\$185.04</b>	SGIH26-3	SGTN-3-DC656	SGTBN19-5
SGTBN25,4-6S	85330-Z30A1	\$385.14	<b>\$195.25</b>	SGIH32-3	SGTN-3-DC656	SGTBN25-4-6

### Blade & Insert Sets

Set Desc.	Set Part No. 733101-	List Price	Sale Price	(1) Blade	(10) Inserts
SGIH26-3S	85360-Z30A1	\$185.45	<b>\$102.40</b>	SGIH26-3	SGTN-3-DC656
SGIH32-3S	85364-Z30A1	\$198.92	<b>\$110.10</b>	SGIH32-3	SGTN-3-DC656

**Up to  
30% OFF  
List Price**

## NEW Multi-Application

Turning and Grooving | Profiling and Parting Off

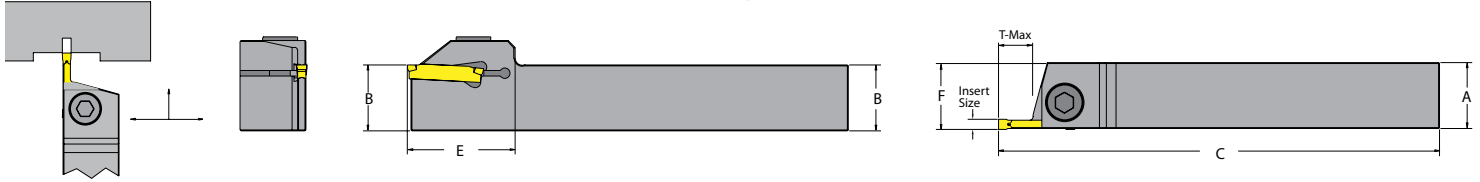

### SHORT Depth of Cut : T-Max 0.354"

#### DETGF External Turning Grooving Toolholders

Description	Part No. 733101-		List Price	Sale Price	Insert Size	T-max	A	B	L	H	F	F1	Insert	Lock Screw	Hex Key	
	Right Hand	Left Hand														
DETGFR/L 12-030C-S09	63606-Z30A1	63607-Z30A1	\$92.52	<b>\$66.12</b>	3.0mm	.118/.125"	0.354"	0.750"	0.750"	5.00"	0.750"	0.699"	0.758"			
DETGFR/L 16-030B-S09	63614-Z30A1	63615-Z30A1	\$103.46	<b>\$73.90</b>	3.0mm	.118/.125"	0.354"	0.625"	0.625"	4.50"	0.625"	0.574"	0.633"	DNT_-2230_	CS-M0616	AHK-50
DETGFR/L 85-030D-S09	63622-Z30A1	63623-Z30A1	\$114.35	<b>\$81.68</b>	3.0mm	.118/.125"	0.354"	1.000"	1.250"	7.00"	1.250"	1.199"	1.258"			

### MEDIUM Depth of Cut : T-Max 0.551"

#### DETGF External Turning and Grooving Toolholders

Description	Part No. 733101-		List Price	Sale Price	Insert Size	T-max	A	B	L	H	F	F1	Insert	Lock Screw	Hex Key	
	Right Hand	Left Hand														
DETGFR/L 12-030C-M14	63636-Z30A1	63637-Z30A1	\$98.01	<b>\$70.01</b>	3.0mm	.118/.125"	0.551"	0.750"	0.750"	5.00"	0.750"	0.699"	0.758"			
DETGFR/L 16-030B-M14	63644-Z30A1	63645-Z30A1	\$108.90	<b>\$77.79</b>	3.0mm	.118/.125"	0.551"	0.625"	0.625"	4.50"	0.625"	0.574"	0.633"	DNT_-2230_	CS-M0616	AHK-50
DETGFR/L 85-030D-M14	63652-Z30A1	63653-Z30A1	\$119.79	<b>\$85.56</b>	3.0mm	.118/.125"	0.551"	1.000"	1.250"	7.00"	1.250"	1.199"	1.258"			

### LONG Depth of Cut : T-Max 0.787"

#### DETGF External Turning and Grooving Toolholders

Description	Part No. 733101-		List Price	Sale Price	Insert Size	T-max	A	B	L	H	F	F1	Insert	Lock Screw	Hex Key	
	Right Hand	Left Hand														
DETGFR/L 12-030C-L20	63666-Z30A1	63667-Z30A1	\$103.46	<b>\$73.90</b>	3.0mm	.118/.125"	0.787"	0.750"	0.750"	5.00"	0.750"	0.699"	0.758"			
DETGFR/L 16-030B-L20	63674-Z30A1	63675-Z30A1	\$114.35	<b>\$81.68</b>	3.0mm	.118/.125"	0.787"	0.625"	0.625"	4.50"	0.625"	0.574"	0.633"	DNT_-2230_	CS-M0616	AHK-50
DETGFR/L 85-030D-L20	63682-Z30A1	63683-Z30A1	\$125.24	<b>\$89.45</b>	3.0mm	.118/.125"	0.787"	1.000"	1.250"	7.00"	1.250"	1.199"	1.258"			

### Neutral DNTF Turning and Grooving Inserts

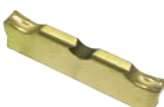
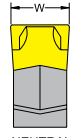
Application	Non Ferrous		Ferrous and Non Ferrous		Ferrous		Insert Data						
	General Turning Operation at Low to Medium sfm		High Performance Operation at High sfm	General Turning Operation at Medium sfm	General Turning Operation at Medium to High sfm	Unfavorable Turning Operation at Medium sfm	  NEUTRAL	Width + .05	Radius	Lead Angle			
Material	Aluminum, Cast Iron, Stainless Steel		Non Ferrous, Aluminum, Aerospace Alloys, High Temper Alloys, Cast Iron, Copper/Brass, 300 Series Stainless Steel		Carbon and Alloy Steel, 400 Series Stainless Steel								
Insert Coating	Uncoated		PVD AlCrN	PVD TiAlN/WC/C	PVD TiN TiAlN TiN	PVD TiAlN/WC/C							
Industry Standard Insert Grade	(A.N.S.I.) C2-C3 K25-M30 -S25-H25		(A.N.S.I.) C2-C3 P10 M10 K10 S10 H10	(A.N.S.I.) C2-C3 P35 M35 K25 S25 H25	(A.N.S.I.) C6-C7 P15-P35 M20-M35	(A.N.S.I.) C5-C6 P25-P50 M25-M40							
Insert Aptitude	Wet		Dry	Wet	Wet	Wet							
Dorian Insert Grade	DK25		DKP15V	DKP35-F	DASP35B	DHP440-F							
	UPC No. 733101-		UPC No. 733101-	UPC No. 733101-	UPC No. 733101-	UPC No. 733101-							
DNTF-223003-EN	82366-Z30A1		82367-Z30A1	82368-Z30A1	82370-Z30A1	82371-Z30A1							
List Price	\$14.24		\$18.05	\$16.61	\$19.07	\$16.61	3.0	0.118	0.3	0.012	0°		
Sale Price	\$10.19		\$12.89	\$11.86	\$13.62	\$11.86							

# Multiple Application

**Turning and Grooving | Profiling and Parting Off**

***Productive  
and  
Simple!***

